

VIEW D-D

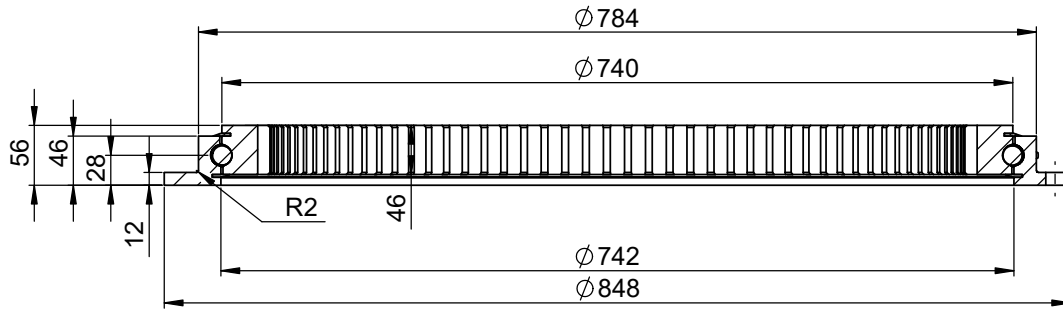

Gear data					
Module	m_n	6.35	Addendum	h_a	5.08
No. of teeth	z	104	Tooth height	h	11.43
Pressure angle	α_n	20°	Modification coefficient	x_n	-
Helix angle		0	Helix position		-
common normal line	$W \frac{Ebms}{Ebmi}$	224.829 ^{-0.2} _{-0.4}		Cross-tooth No.	
				k	12

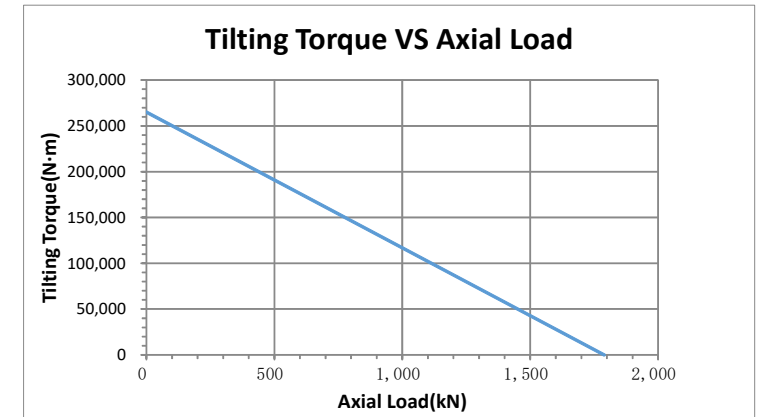
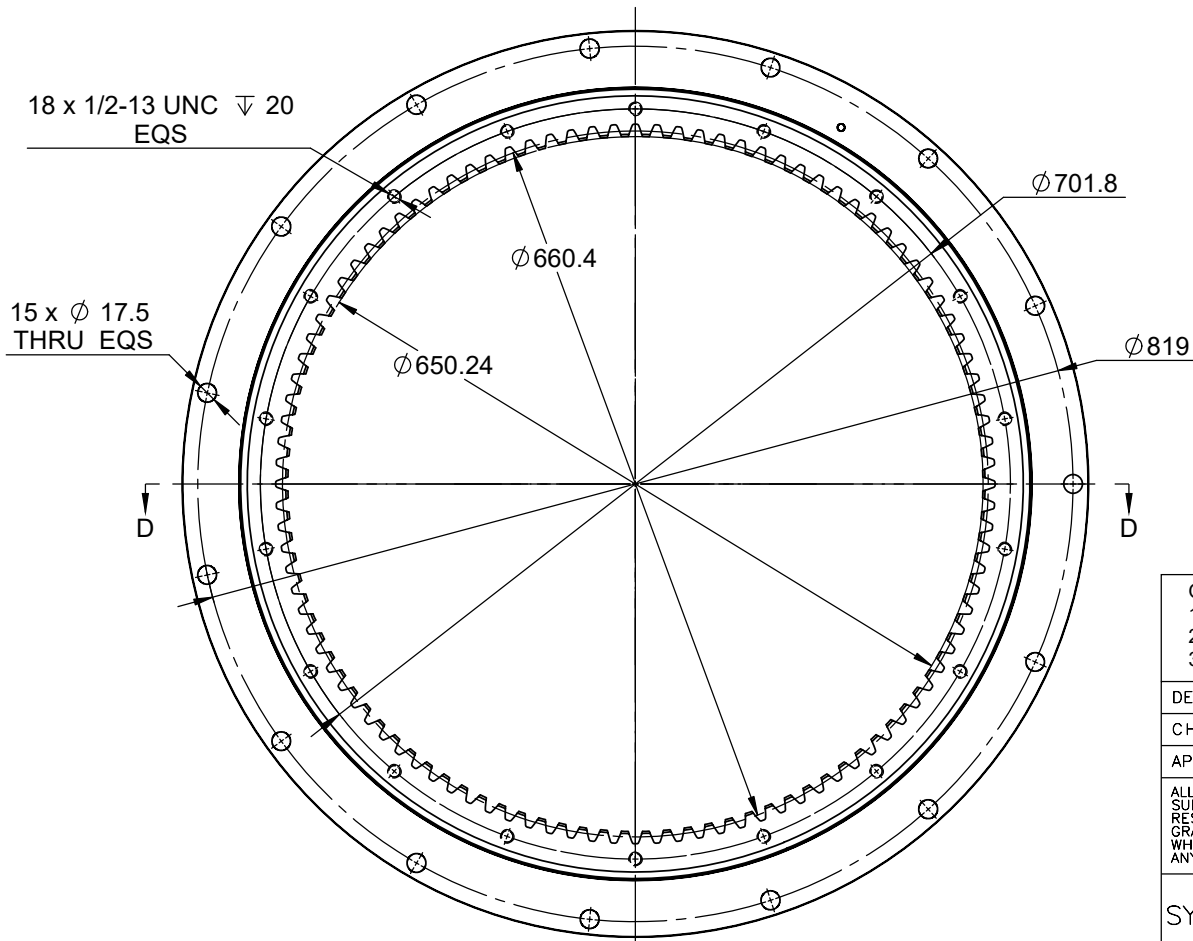

On the dimensions with parenthesis:

- 1) These are for reference only.
- 2) This is a preliminary dimension and may vary in the actual product.
- 3) If this dimension is important to the application, please communicate this back to KMI.

DESIGNED BY	CKL	2021/03/04
CHECKED BY	CF	2021/03/04
APPROVED BY	WMS	2021/03/04

KMI GROUP
www.kinematicsmfg.com

ALL PROPRIETARY RIGHTS IN THE SUBJECT MATTER HEREOF ARE RESERVED, AND NO PERMISSION IS GRANTED TO REPRODUCE THIS PRINT IN WHOLE OR IN PART, OR TO DISCLOSE ANY OF THE INFORMATION TO OTHERS.	WEIGHT	SCALE
	53.21 Kg	1:5

SLEWING RING

SYMBOL ISO	SIZE	A3	SHEET	1/3
		THE TOLERANCE NOT MENTIONED IS REFERRED TO ISO2768-VL CASTING TOLERANCE ISO 8062-CT10		

KRE-29N1Z

REV
A